

The impedance of electrical storage cells

N. A. HAMPSON, S. A. G. R. KARUNATHILAKA, R. LEEK*

Department of Chemistry, University of Technology, Loughborough, Leicestershire, UK

Received 20 May 1979

A brief review of the theory pertaining to the impedance of electrolytic cells is presented. Differences between the operational representations of cell impedances in the fields of electrochemistry and electrical engineering are noted. The experimental data on the impedance of complete batteries, available from the literature, is critically reviewed. The results are discussed in terms of the generation of a non-destructive, *in situ*, state-of-charge test.

Contents

1. The operational representation of impedance data and circuit response analysis
2. The impedance of an electrode
3. The effect of porosity
4. The description of energy storage cells as electrical networks
5. The experimental results
6. The impedance of cells as an *in situ* test of energy availability

1. The operational representation of impedance data and circuit response analysis

When a constant potential difference is maintained between two electrodes in a cell, a direct current flows between them. If an alternating voltage v of relatively small amplitude is superimposed on the potential difference, the current contains an alternating component of amplitude i . When the amplitude of the alternating voltage v varies sinusoidally with time and with a frequency f , we may write

$$\omega = 2\pi f$$

$$v = V_{\max} \sin \omega t$$

$$i = I_{\max} \sin (\omega t - \phi)$$

and

$$Z_e = \frac{V_{\max}}{I_{\max}} \arg (\phi) = |Z_e| \arg (\phi)$$

where Z_e is the impedance of the cell.

When ϕ is a negative quantity, the current leads the voltage by an angle ϕ and the impedance may be represented by either of the capacitive-resistive circuits shown in Figs. 1a and b where the corresponding equations for Z_e are given in conventional complex form and Z_e is plotted on an Argand diagram. Conversely, when ϕ is a positive quantity, the current lags the voltage by an angle ϕ and the impedance may be represented by either of the inductive-resistive circuits shown in Figs. 1c and d. The loci illustrated in Figs. 1b and d are easily shown to be circles of radius

$$\frac{R}{2} = \frac{1}{2\omega C} = \frac{\omega L}{2} \text{ when } \phi = 45^\circ.$$

The above equations show that capacitive reactance appears as a negative quantity on the Argand diagram (otherwise known as the complex plane) and this is in accordance with the conventional presentation used in practice in electrical engineering. In the electrochemistry of cells, the reactances most often encountered are capacitive and, for convenience, it has become standard practice to employ the first quadrant of the complex plane for their presentation. The inductive reactance of cells is also being studied, particularly at the higher frequencies of the applied alternating voltage. In

* Department of Electronic and Electrical Engineering

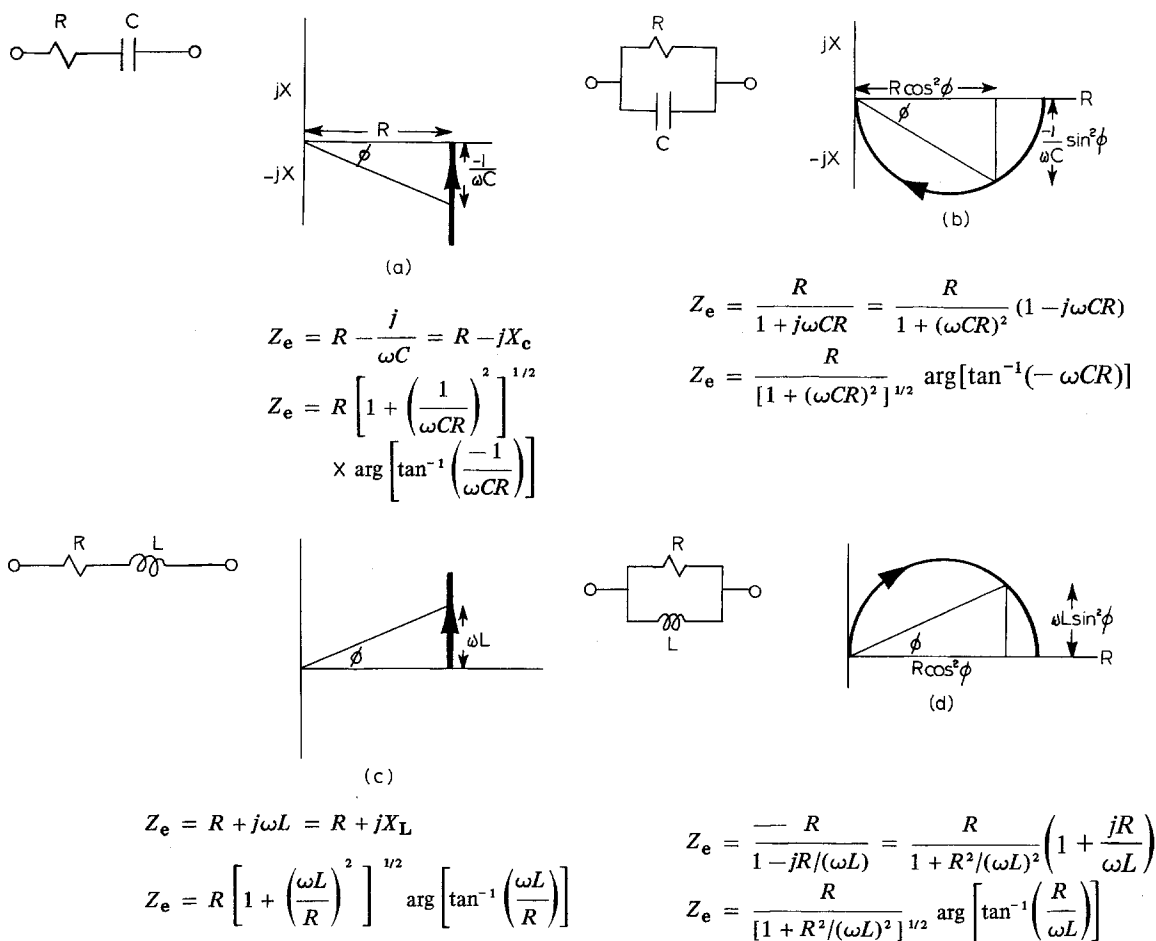

Fig. 1. Loci of impedance for simple networks.

this review we have taken the step of making the diagrams which illustrate impedance on the complex plane compatible with those used in practice in electrical engineering.

The impedance of an electrolytic cell may be represented by an equivalent electrical network such as that shown in Fig. 2 where R_Ω represents the resistance of the electrolyte and the metal electrodes of the cell. If no electrode reaction takes place, the currents which flow due to variation in potential difference between the electrodes is solely due to charging and discharging of a double-layer capacitance represented by C in Fig. 2.

When account is taken of the reactions taking place at the electrodes, the alternating current which flows as a result of the variation of v is dependent on the potentials of the electrodes and the concentrations of the substances involved at the surfaces of the electrodes. The part of the

alternating current which depends on the potential of the electrodes is in phase with the voltage and may be represented by a transfer resistance R_t as shown in Fig. 2. The part which depends on the concentration of substances is in turn determined by the process of diffusion of those substances and Warburg showed that this part of the current may be thought to flow in an impedance Z_W consisting of a resistive and capacitive component in series, the magnitude of each component being inversely proportional to the square root of the frequency. On an Argand diagram, Z_W is represented by a straight line of slope 45° [1, 2].

The electrochemical reactions which take place in the electrolyte are governed by rate constants and they produce intermediate species which are adsorbed by the electrodes [1, 2]. Since this activity covers only a fraction of the total electrode area, when the alternating voltage v is super-

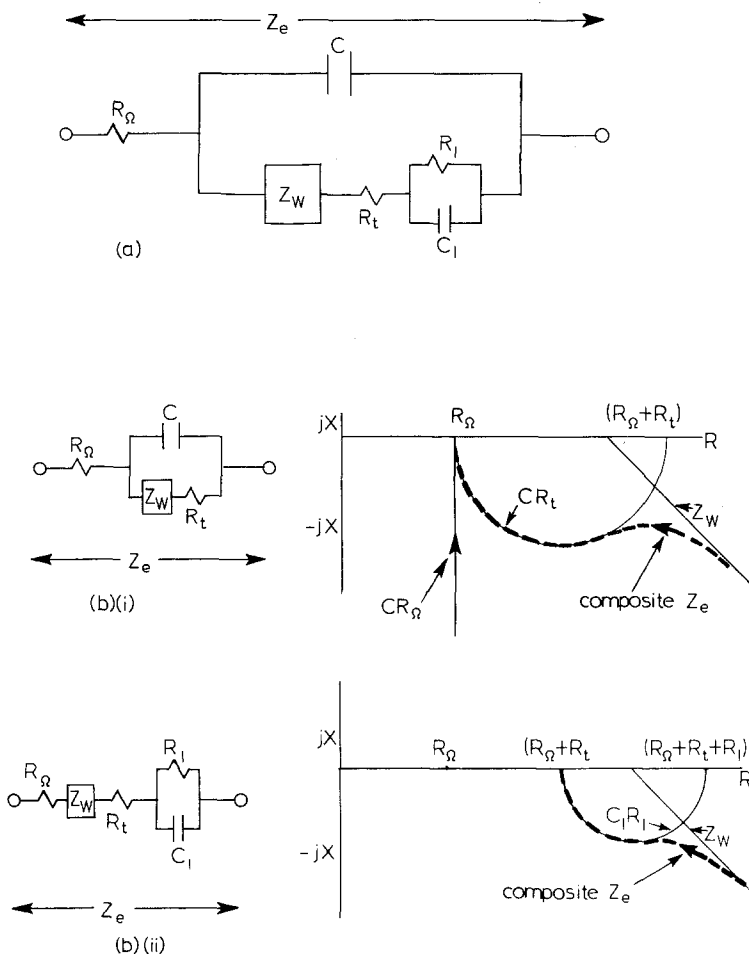

Fig. 2. Equivalent circuit of an electrolytic cell. (a) Complete cell; (b) (i) circuit and locus of Z_e omitting $C_1 R_1$; (b) (ii) circuit and locus of Z_e omitting C .

imposed on the constant potential difference between the electrodes, this fraction fluctuates at the same frequency but differs in phase angle from v . Also, when the potential difference is constant, the current density varies as a function of the changing fraction. The alternating current i may then lead v so that the process may be represented by C_1 and R_1 in parallel as shown in Fig. 2. If the electrochemical reactions involve two adsorbed intermediate species, an additional equivalent circuit consisting of a capacitance C_2 connected in parallel with a resistance R_2 may be added in series with the former combination of C_1 and R_1 . Since a change in v cannot be followed immediately by a change in the fraction, the fact that the current density is itself a function of the potential is accounted for in the equivalent circuit by the series resistance R_t referred to above, representing the transfer resistance per unit area

of the electrode under conditions where the fraction is held constant.

Making use of Figs. 1a and b, the equivalent circuit of Fig. 2a leads to the diagrams shown in Figs. 2b and 3 where the complete circuit and the associated variation in the impedance of the cell is built up in stages. Depending on the relative magnitudes of the components, the composite curve for the complete circuit may fall anywhere between those shown in Figs. 2b (i) and (ii) such as the curve indicated in Fig. 3a.

Sometimes the impedance of a cell has been observed to contain a predominantly inductive reactance. This has been measured at low frequencies with solutions of iron [3] and in batteries [4]. Inductive reactance has also been measured at high frequencies. One way in which the structure might behave like an inductance would be if there were a delay in time between the arrival of current and its

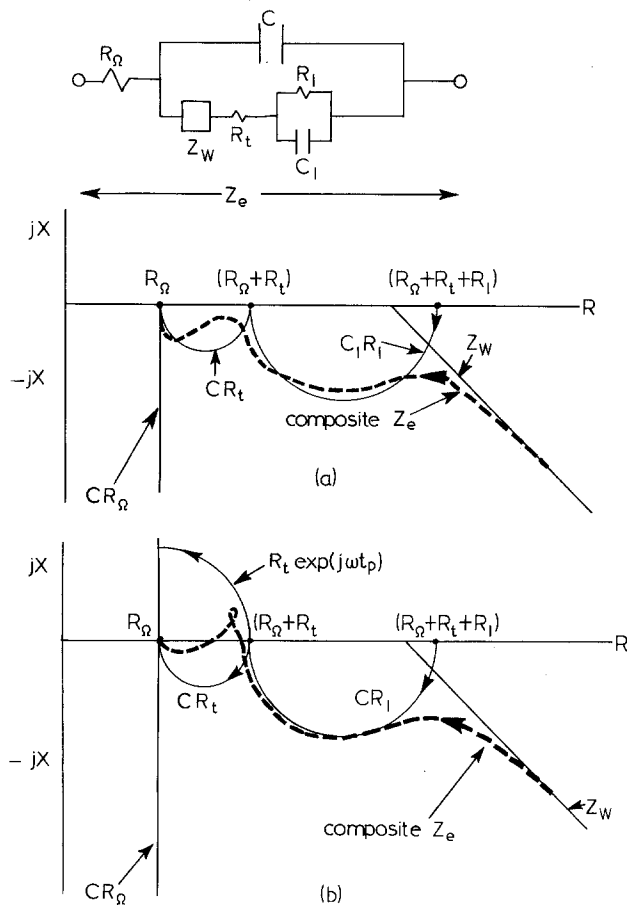

Fig. 3. Equivalent circuit of an electrolytic cell. (a) Locus of Z_e for complete circuit, R_t fixed; (b) locus of Z_e for complete circuit, $R_t = R_t \exp(j\omega t_p)$.

general absorption into the body of the electrode, particularly if the surface were rough. Assuming that the time taken for current to be propagated down fissures in the electrode is the same, t_p say, for all frequencies, then the phase angle of the delay is ωt_p . An angle of 8° has been observed at a frequency of 8 kHz so that $t_p = 3 \mu\text{s}$. A lagging phase angle due to such a delay time may be introduced into the equivalent circuit of Fig. 2a by ascribing to R_t an argument in the complex plane while its modulus remains fixed, namely R_t becomes $R_t \exp(j\omega t_p)$ which, at low frequencies when $\omega \ll 1/t_p$, reduces to the resistance R_t as before. The associated variation on the Argand diagram would then become as shown in Fig. 3b.

Another mechanism which would make the cell behave as if it contained inductive reactance would be that where a change in the fraction of the total electrode area covered by the activity of the intermediate species, referred to above, became inversely

proportional to a corresponding change in the alternating voltage v . With the current density remaining constant, this would result in an effective negative capacitance $C_\theta = -dq/dv$, say, but if C_θ were constant at all frequencies, the equivalent pseudo-inductance would have the frequency-dependent value $1/(\omega^2 C_\theta)$.

2. The impedance of an electrode

The method of investigating electrochemical processes by determining electrode impedance as a function of frequency was first introduced by Ershler [5] and Randles [6] more than 30 years ago. The method has been reviewed notably by Grahame [1] and Sluyters-Rehbach and Sluyters [2] and recent extensions have been incorporated into the literature by Armstrong, Bell and Metcalfe [7].

For the electrode reaction

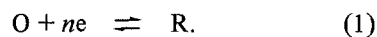

the electrical analogue is shown in Figs. 2 and 3 where Z_W represents the (Warburg) impedance characteristic of diffusional mass transport in solution.

Z_W may be represented by a series combination of resistance and capacitive reactance

$$Z_W = \sigma\omega^{-1/2} - j\sigma\omega^{-1/2} \quad (2)$$

where σ is the Warburg coefficient.

$$\sigma = \frac{RT}{\sqrt{2n^2F^2}} [(C_O D_O^{1/2})^{-1} + (C_R D_R^{1/2})^{-1}] \quad (3)$$

R_t is a resistance characteristic of the charge transfer process

$$R_t = \frac{RT}{nFi_0} \quad (4)$$

It has been customary [8] to represent the frequency dependence of this simple electrode process by plotting the impedance of the complex plane as shown in Fig. 2b (i). At low frequencies, when the effects of the double-layer capacitance may be neglected, the value of the impedance tends to that of Z_W which, as stated above, is represented on the complex plane as a straight line of slope 45° . The semicircle arises from the range of values of frequency for which ω shrinks to a value small enough for the analogue to behave as a resistance and capacitance in parallel. Ultimately at high frequencies, the locus tends to the asymptote representing C and R_Ω in series in Fig. 2b(i).

The simple process has been extended to incorporate the effects of surface processes by Grahame [1]. However, his representation is inferior to the more recent representation by Sluyters [2]. The adsorption of species is represented in the simple electrode analogue above by the incorporation of extra resistances and capacitances. If the adsorbate is not electro-active the effect is clearly to modify the double-layer capacitance and the effect of 'low' double-layer capacitances due to the adsorption of impurity from solution is well known. If the adsorbed species are able to undergo a redox reaction then the effect is an extra resistance and capacitance shunting the double layer. The first example of this effect was described by Laitinen and Randles [9].

The effect of the adsorption of the species (or intermediates) of the electrode process results in the appearance of extra components in the 'elec-

trode reaction line' shunting the double-layer.

Impedance loci of the type shown in Figs. 2b (ii) and 3 are examples of this behaviour. An important theoretical example is shown in Fig. 3a where the electrode analogue for an electro-crystallization process proceeds via the participation of adsorbed species [10]. The review by Armstrong *et al.* [11] extends the discussion of complex reactions to passivity and nucleation and growth processes. Here the impedance spectra due to two-dimensional nucleation and growth have been calculated. It was demonstrated that severely distorted semicircles in the locus on the complex plane are to be expected as distinct from ones found for the adsorbed intermediate case (adatom model) and this method of representation may in principle provide a means of distinguishing between the two cases.

3. The effect of porosity

The requirement that storage cells possess adequate storage capacity has resulted in the use of electrodes having a high specific surface area. These electrodes are often porous in the sense that the pore length is relatively large compared to the pore diameter and the electrode reacts in depth. The modifications to the planar electrode behaviour introduced by this feature are gross [12]. We note for example that for a simple idealized pore structure a simple double-layer charging current is proportional to $t^{-1/2}$ rather than t^{-1} ; the Tafel slope $d(\ln i_{CT})/dE$ is half what it would be for a planar electrode of identical material; the field equation for a diffusional process at an electrode becomes similar to the charge transfer field equation. In 1968, de Levie [12] made a review of the relevant literature and it is clear from that review and papers published since 1968 that it will be very challenging to attempt to make an extension of the theory of the impedance of planar electrodes to those of the porous type. However, it is an extension of the theory which will have to be made if the behaviour of most commercial cells is to be better understood. Although the amount of published work on this subject is small, some valuable conclusions may be drawn from it. These conclusions arise from the recognition that, in principle, for a planar electrode the current lines are normal to the

electrode surface but for a porous electrode the lines are effectively parallel to the surface. The impedance of a planar electrode is the sum of the impedances of the components representing electrode processes but the impedance of a porous electrode is the geometric mean of those components. This causes the impedance representing the diffusional mass transport in porous electrodes to be dependent on terms proportional to $\omega^{-1/4}$ in place of those containing $\omega^{-1/2}$ given in Equation 2 for a porous electrode. The high frequency semicircle which cuts the real axis normally for the plane electrode comes off at $\pi/4$ in the case of the porous one. Amplitudes are also affected; the vector amplitude for the porous electrode contains the corresponding component for the plane electrode to the half-power. The most convenient method of dealing with the porous electrode is to use the method of 'squaring' described by de Levie [12]. In this, the phase angle in the locus of the impedance is doubled and the amplitude is squared.

A further complication observed in the frequency response is the inductive behaviour sometimes observed at high frequencies. Gutman [4] has discussed this effect and concluded that, whenever the electrode system behaves as a negative resistance and furnishes energy to the measuring device, an inductive component is present. He also instances the case where desorption occurs with increasing potential so that $d\Gamma/dE$ is negative. These behaviours would, however, be expected to be most significant at low frequency rather than high and Epelboin *et al.* [3], for example, have provided both theoretical and experimental corroboration. Gutman [4] has pointed out also that, if the electrolyte is viscous, the current at the electrode interphase may not be a truly harmonic quantity and that the equation

$$i = I_0 \sin \omega t \quad (5)$$

may not hold. This gives rise to a lag in the electrode response and a corresponding inductive region at high frequency due to energy storage and in the limit a phase angle of $-\pi/4$ (lagging) should be observed at all frequencies. Darby [13] has shown how inductive resistances arise naturally from mass transport and electrochemical reaction which occurs simultaneously over a distributed region of the electrode. At sufficiently high fre-

quencies, the phase angle of the faradaic impedance is negative. This arises because of a change in reactant concentration with depth inside the porous electrode which is inapplicable with a solid electrode. Keddam *et al.* [14] confirm that these effects can occur with a lead-acid cell at certain stages of charge. We have also noted similar effects in connection with the frequency response of lead dioxide electrodes in sulphuric acid [15].

We conclude that the presence of porosity will have great effects on the impedance of electrodes at all frequencies and, in particular, it may lead to the impedance becoming inductive at high frequencies.

4. The description of energy storage cells as electrical networks

The vast majority of electrochemical research work concerning impedance has been undertaken on cells which have been designed so that only the behaviour of one electrode is studied. This is usually accomplished by arranging the cell with a microelectrode of interest together with a counter electrode having a large area and an impedance at least 100 times smaller than that of the microelectrode. The potential of the microelectrode is measured against a reference electrode and its potential fixed. In an a.c. experiment the potential of the microelectrode has a relatively small a.c. component (± 5 mV) which is superimposed on the fixed potential. By working at the equilibrium potential, the frequency response contains kinetic information corresponding to that potential. The kinetics of the electrode process may be measured for each of a range of values of fixed potential. If the impedance is determined from measurements including that of the a.c. voltage, e.g. in a correlation experiment rather than using bridge techniques, then the use of the reference electrode as a third electrode enables the impedance of each cell electrode to be measured independently.

For a commercial energy storage cell, the system is far removed from the precise conditions described above. Electrodes may be porous, electrolyte solutions may be present only in limited amounts (dry cells) and separator materials, incorporated into the cell in order to avoid short circuits and often to provide a reservoir for the

electrolyte, may shield the electrodes from each other to some extent. The cell designer, however, generally contrives to arrange a flow of current which is normal from electrode to electrode since, other things being equal, this ensures that the efficiency of the cell is a maximum. A further complicating factor has been claimed to be that electrical contacts may produce inductive effects; although this may occur with poor contacts, it is the experience of the present authors that, in general, the inductances are small enough to be neglected.

The cell therefore may be considered as a complex series circuit. It is quite likely that one electrode may dominate the impedance behaviour of the cell. For example, the zinc can negative in the Leclanché dry cell dominates and although the MnO_2/C electrode is porous these effects are not encountered (at least early on in the discharge life) [16]. Every cell, therefore, must be discussed in its own context and in general no overall picture can be drawn.

5. The experimental results

There are very few published data on the impedance of commercial cells. This is because of difficulties due to constructional and descriptonal uncertainties in the case of small 'dry cells' as, for example, it is generally quite difficult to arrange for a satisfactory reference electrode for the a.c. experiment. It is particularly difficult to superimpose small alternating currents on the current flowing in a cell having a large energy storage, such as a submarine battery having a capacity of 10^4 A h, as this would require the use of a potentiostat with an output of 100 A. The small amount of work published on this subject generally concerns cells of small capacity but experiments on automotive batteries of 100 A h capacity are described in some early papers by Willihnganz [17, 18]. Experiments were made in the range 30–3000 Hz and although the characteristic behaviour of porous electrodes was not available to the author he estimated that his cell had an effective lead electrode surface area of 0.5×10^6 cm². A more recent paper by Winter *et al.* [19] describes an investigation of the a.c. or dynamic resistance R_{ac} and the d.c. resistance R_{dc} of a zinc/mercury oxide primary cell. These

authors found that at sufficiently high frequencies (> 6 kHz), R_{ac} was much lower than R_{dc} (confirming Vinal's [20] early findings) and was independent of frequency.

The difference between R_{dc} and R_{ac} was interpreted as a 'polarization resistance' which increased during the d.c. discharge of the cell from the undischarged condition. No attempt was made to relate the behaviour of the cell to the dominating effect of either electrode under dynamic conditions but, seen in retrospect, this would have been difficult to achieve since both electrodes were porous (positives, graphite + HgO ; negatives, amalgamated zinc powder).

Latner [21] measured the capacitance of a nickel-cadmium battery as a function of various degrees of discharge using a bridge operating at 60 Hz. The fact that the capacitance diminished markedly with the degree of discharge remained unexplained.

A much more satisfactory investigation of the impedance of lead-acid cells has been reported by Keddam *et al.* [14] using a 7 A h 6 V battery. Measurements were made on the fully charged battery poised at the equilibrium potential over the frequency range 10 kHz to 0.001 Hz. The impedance was inductive at high frequency and exhibited a locus coming off the real axis with a slope of approximately $\pi/4$. Similar measurements were made on a fully-discharged cell for which the locus of impedance was found to contain a region having the same slope but was otherwise different. Under galvanostatic discharging conditions, a significant difference was that the phase angle of the impedance of the fully-discharged cell was reduced to $\pi/8$. Although no interpretation of the data was given, impedance measurements made using a reference electrode indicated that there were only slight differences between the time constants for the processes occurring at the positive and negative electrodes.

6. The impedance of cells as an *in situ* test of energy availability

A cell may fail due to any one of a number of causes. The most obvious cause is lack of active material but many more may be cited, for example, the development of highly resistant films on either the electrodes or the plates, the loss of

electrical conductivity in the ohmic sense, the deterioration of either active material due to local action at the electrode, or leakage of electrolyte. Theoretically, each mode of cell failure requires a separate test, for example, effective electro-active concentration can be determined by the Nernstian potential but any other shortcomings are ignored. A complete cell condition diagnosis would be based on the results of a number of tests which would provide data for the simultaneous solution of a number of linear equations.

Since the investigations referred to above have shown that the impedance of a cell depends on its state-of-charge, it follows that a frequency-response experiment provides a series of data from which it should be possible to predict the cell condition. Moreover, the change in impedance with the degree of discharge is of much greater magnitude than the corresponding change in cell open-circuit voltage (which is the only readily-available test).

This has been demonstrated by Keddum *et al.* [14] in the case of the lead-acid battery, the difference in the impedance spectra between the fully-charged battery (measured between the terminals 6 V 7 A h at zero current) and the fully-discharged battery was quite marked particularly at low frequencies (1–0.001 Hz). The most noteworthy difference was that the phase angle at low frequency for the fully-discharged battery was approximately the expected $\pi/4$ value for a planar electrode under diffusion control whereas the fully-charged battery exhibited a much smaller phase angle typical of the porous electrode.

Very recent papers from Bangalore have dealt specifically with the state-of-charge of the nickel-cadmium [22], lead-acid [23] and the zinc- and magnesium-manganese dioxide [24] cells. For the nickel-cadmium cell Sathyanarayana *et al.* [22] find that it is possible to analyse the experimental cell impedance data on the basis of a uniform transmission line analogue equivalent circuit of resistance and capacitance. Both resistive and capacitive components of the electrode analogue varied with state-of-charge. However, the most satisfactory correlations were obtained between either 'phase shift' and state-of-charge (< 100% increase over the range) or 'cell capacitance' and state-of-charge (< 50% decrease over the range). In a thorough analysis of the frequency responses a kinetic interpretation of the impedance data was

given in terms of the diffusion of ions along the axes of the electrode pores and subsequent reaction at the pore wall-active material interface.

For the lead-acid cell [23] a progressive shift in the impedance parameters in the frequency range 15–200 Hz with state-of-charge was observed; however, the curves were parabolic so that their usefulness as a state-of-charge indication in this frequency range was limited (cf. Keddum *et al.* [14]). Here also the authors offer an explanation of the kinetic processes in terms of the diffusion of ions within porous electrodes and reactions at the pore wall-active material.

For the Mg-MnO₂ and the Zn-MnO₂ cells Gopikanth *et al.* [24] find that pronounced fluctuations occur in the magnitudes of the electrode impedances as the discharge takes place. These are convincingly traced to film formation and breakdown so that a determination of the state-of-charge in the presence of these processes is not possible.

In connection with cells of the Leclanché, alkaline Zn-MnO₂ and HgO-Zn types, in the present review the authors have been able to confirm that gross changes in the impedance spectra do occur as the cells are discharged [25]. It has been found possible to isolate kinetic parameters, identify pitting processes (development of porosity) and identify pore-blocking processes (loss of porosity) as cells both age and discharge. However, it is our conviction that a test embodying more than one frequency will be needed to completely specify the state-of-charge.

In conclusion, there is a need in present day battery technology for an efficient state-of-charge test to cover behaviour at all rates of discharge. The cell impedance may well offer that facility.

Acknowledgement

We thank Dr T. J. Sinclair of MOD for helpful discussion and the Procurement Executive of the Ministry of Defence for financial support (to S.A.G.R.K.).

References

- [1] D. C. Grahame, *J. Electrochem. Soc.* **99** (1952) 370 C.
- [2] M. Sluyters-Rehbach and J. H. Sluyters, in 'Electroanalytical Chemistry' Vol. 4 (edited by A. J. Bard) Dekker, New York (1970) p. 1.

- [3] J. Epelboin, M. Keddam and J. C. Lestrade, *Disc. Faraday Soc.* **56** (1973) 264.
- [4] F. Gutman, *J. Electrochem. Soc.* **112** (1965) 94.
- [5] B. V. Ershler, *Dis. Faraday Soc.* **1** (1947) 269.
- [6] J. E. B. Randles, *ibid* **1** (1947) 11.
- [7] R. D. Armstrong, M. F. Bell and A. A. Metcalfe in 'Electrochemistry', Vol. 4 (edited by G. J. Hills and H. R. Thirsk) The Chemical Society, London (1977) p. 98.
- [8] J. H. Sluyters, *Rev. Trad. Chim.* **79** (1960) 1092.
- [9] H. A. Laitinen and J. E. B. Randles, *Trans. Faraday Soc.* **51** (1955) 54.
- [10] M. Fleischmann, S. K. Rangarajan and H. R. Thirsk, *ibid* **63** (1967) 1240, 1251, 1256.
- [11] R. D. Armstrong and A. A. Metcalfe, *J. Electroanalyt. Chem.* **71** (1976) 5.
- [12] R. de Levie, 'Electrochem. Eng.', Vol. 6, (edited by Delahay and Tobias) p. 329.
- [13] R. Darby, *J. Electrochem. Soc.* **113** (1966) 392, 496.
- [14] M. Keddam, S. Stymar and H. Takenouti, *J. Appl. Electrochem.* **7** (1977) 539.
- [15] P. Casson, N. A. Hampson and K. Peters, *J. Electroanalyt. Chem.* **97** (1979) 21.
- [16] N. A. Hampson, S. A. G. R. Karunathilaka, R. Leek and C. J. Sinclair, to be published.
- [17] E. Willihnganz, *Trans. Electrochem. Soc.* **79** (1941) 253.
- [18] E. Willihnganz, *J. Electrochem. Soc.* **102** (1955) 99.
- [19] J. L. Winter, J. Y. Broslin, R. L. Ross, H. A. Leopold and F. Rothwarf, *ibid* **122** (1975) 1434.
- [20] G. W. Vinal, 'Storage Batteries', 3rd Edn., J. Wiley and Sons, New York (1940) p. 328.
- [21] N. Latner, *Rev. Sci. Inst.* **40** (1969) 364.
- [22] S. Sathyanarayana, S. Venugapalan and M. L. Gopikanth, *J. Appl. Electrochem.* **9** (1979) 125.
- [23] M. L. Gopikanth and S. Sathyanarayana, *ibid* **9** (1979) 369.
- [24] *Idem*, *ibid* **9** (1979) 581.
- [25] S. A. G. R. Karunathilaka, N. A. Hampson, R. Leek, T. J. Sinclair, unpublished results.